

FD Series



Fire Dampers

- Complies to BS EN 15650
- Tested and assessed installation methods to BS EN 1366-2 and BS 476-20/22
- E classified fire dampers complying with BS EN 13501-3
- FD-AF has been tested both vertically and horizontally. It is installed using single side access without the need to provide fire rated infill material
- Galvanised and stainless steel options
- Microswitch option for remote indication



MANUFACTURERS OF AIR, FIRE AND SMOKE CONTROL PRODUCTS



FD Series

Fire Dampers - Introduction



Introduction

What is a fire damper and why might they be needed?

The FD Series Steel Curtain Fire Damper is designed to stop the spread of fire through ducts, walls, floors and ceilings.

The product range has many features and options to meet the requirements of specifiers, contractors, local and national authorities. Dampers are available to suit both low/medium and high velocity applications.

What is the 'E' classification?

To achieve the classifications to EN13501-3, fire dampers and fire and smoke dampers shall be tested to EN1366-2 and a 300Pa pressure difference is applied across the damper. During the fire test period, the integrity of the seal between the damper and the structure shall not have any gaps larger than 150mm x 6mm. There shall not be any sustained flaming. The largest size of damper to be manufactured for sale as a single section shall be fire tested.

E = Integrity

The maximum leakage permissible at 300Pa corrected to 20°C is 360m³/hr/m² (100 l/s/m²) throughout the fire test period.

Fire dampers should be installed as tested.

Test reports showing testing to EN 1366-2 should be acceptable to meet the requirements of BS 476-20/22, but the reverse is definitely not the case and no classifications are available.

Some applications (fan off) allow the use of tests undertaken to BS 476-20/22 and this is allowed worldwide in areas outside of the EU. However, as a word of caution, in whichever case, the correct model must be selected, to match fire resistance time with installation method and with the supporting construction (wall or floor).

BSB have a policy of continued testing and product certification to try and provide as broad a number of installation methods as possible.

BSB also follow regulation and standards development very carefully to provide input on changes and to be able to pass on relevant information to designers, specifiers, building control authorities (BCA's) and installers.

The FD Series Range

The BSB FD series is available in a variety of vertical or horizontal mounting configurations from 100mm x 100mm to 1200mm wide x 1000mm high.

Type FD Rectangular Spigot

A - Blades in airstream on heights greater than 300mm.

B - Blades held clear of the airstream.

Type FD Circular Spigot

C - Blades held clear of the airstream.

Type FD In-Duct

I - Blades and case within airstream.

Type FD Flat Oval Spigot

O - Blades held clear of the airstream.



FD Features and Benefits

- Tested and classified installation variants of the FD are available to cover masonry walls, dry walls and floors. These cover the majority of applications/supporting constructions that are required to maintain compartmentation.
- All BSB tested installation methods give at least a E120 classification, usually only limited by the wall construction used.
- Sleeve and angle methods, HEVAC frame methods and cleat and drop rod methods are available.
- Some rarer installation applications are covered by assessment/test information to BS 476-20/22.
- Minimum size 100mm x 100mm.
- Maximum single section size 1200mm x 1000mm.
- In millimetre increments.
- Multi-section configurations are available to specific customer requirements, but will be subject to BCA approval.
- Standard construction is a fully welded galvanised steel case, which gives a casing leakage that complies with Class C ductwork leakage specifications.
- Other combinations of galvanised mild steel, type 1.4016 (430) and 1.4401 (316) stainless steels for the blades and case are available to specific customer requirements.
- The BSB FD has a strong and robust design to both meet the exacting fire testing requirements and be resilient to site handling. This is supported by sound production techniques which result in a quality product.
- All the above, supported with BSB's enviable delivery performance, provide an unbeatable combination.

Testing and Conformities



See installations section for full details.

E Classification (BS EN 1366-2/BS EN 13501-3)

- BSB FD fitted with HEVAC frame
 - E 120 - Blockwork/masonry wall
 - E 120 - Concrete floor
- BSB FD fitted with cleats
 - E 60 - Dry partition wall
- BSB FD fitted with angle frame
 - E 120 - Dry partition wall
 - E 120 - Concrete floor
 - E 120 - Masonry Wall

E Classification (BS ISO 10294-1/2)

- As BS EN 1366-2/BS EN 13501-3 above

Corrosion testing (ASTM B117)

- Tested and satisfies LPS 1162

FD Blade leakage (BS EN 1751)

- Class 2

Regulations and Standards

Approved Document B: Fire safety (ADB)

ADB is the UK government's guide to fulfilling the Building Regulations in terms of fire safety. It is available as a free download from the planning portal website.

It gives clear guidance on where fire dampers are to be used and what their performance or classification shall be. The BSB FD fulfils the E classification and reference should be made to the installation method to confirm exact time periods. These will generally be 120 minutes, but may be up to 240 minutes (limited by wall construction).

Health Technical Memo 05/02 (HTM05/02)

HTM05/02 is the Department of Health Firecode - fire safety in the NHS: Guidance in support of functional provisions for healthcare premises.

It basically underlines the requirements stated in ADB, requiring fire damper testing to BS EN 1366-2 and classification to BS EN 13501-3.

It supersedes HTM81 and should be read in conjunction with HTM2025: Ventilation in healthcare premises, as it gives guidance on maintenance and testing.

Building Bulletin 100

BB100 is the Department for Children, Schools and Families document on Fire safety in schools.

It basically underlines the requirements stated in ADB, requiring fire damper testing to BS EN 1366-2 and classification to BS EN 13501-3.

Regulatory Reform (Fire safety) Order (RRFSO)

This is the regulatory requirement that allows people to self fire certificate their buildings. There are requirements for keeping testing and maintenance records for all passive fire protection equipment, which includes fire dampers.

BS EN 1366-2

The fire resistance test standard for fire dampers.

BS EN 15650

Fire Damper product standard. Ventilation for Buildings.

BS EN 1751

The standard for aerodynamically testing dampers. This includes casing leakage.

Other publications

DW 144 (HVCA)

This states the general requirements for HVAC ductwork, including the use of fire dampers. It also states ductwork leakage limits. Normal operating conditions - not exceeding 1000Pa, Classes A & B of DW 144 2016 Specification will apply.

DW 145 (HVCA)

This document will give guidance on the whole process of the selection and installation of fire dampers, with responsibilities and project planning etc.

The Grey Book (ASFP)

This gives further guidance on the application and installation of fire dampers.

Scotland

These are technical standards (AMD's). They give similar guidance to ADB. They already include direct references to the application of European standards. They are obtainable as a free download from the Scottish Executive website.

Typical Tender/Specification Text

Dampers to comply with EN15650.

For maintenance of the integrity of compartmentation the fire dampers shall have an E classification to EN 13501-3.

Curtain fire dampers shall not be used for protection of escape routes and areas with sleeping risk.

Refer to Approved Document B (ADB).

The interlocking ribbed blades shall be held out of the airstream against constant force springs by a fusible link.

The fusible link shall have a melting temperature of 72°C. The link melting shall allow the springs to close the damper.

The fusible link assembly shall be installed so that test release may be made safely from either side of the damper.

The fire damper case shall be fully welded to meet the air tightness test requirements of HVCA. Normal operating conditions - not exceeding 1000Pa, Classes A & B of DW 144 2016 Specification will apply.

The BSB FD fire damper shall have a tested installation method that matches the requirement of the supporting construction into which it is built.

(Tests or assessments of installation methods to BS 476-20/22 may be acceptable if the ventilation design causes the fans to be turned off in the event of a smoke or fire alarm and escape routes and areas of sleeping risk are not being protected).

FD Series

Fire Dampers - Product Specification



Fusible Link Bracket

The Fusible Link Bracket is manufactured from galvanised steel as standard.

Fusible Link

Blades are held in the open position by a straight bar link (fitted as standard) rated at 72°C (162°F) with a formed reinforcing swage and two location holes.

Blades

Formed to provide a continuous interlocking hinge extending the full length with dual swages providing maximum strength and rigidity. Nominally 0.7mm (22swg) thick cold reduced hot dipped galvanised mild steel to BS EN 10346 Grade DX51D + Z275.

Blade material options to order are Ferritic 430 type 1.4016 grade or Austenitic 316 type 1.4401 grade to BS EN 10088-2.

Microswitches

All BSB FD Fire Dampers are available with factory fitted single pole microswitches as optional extras. (See page 15)

Mechanical Visual Indicator

Local visual indication of the blade status is available as an optional extra. (See page 15)

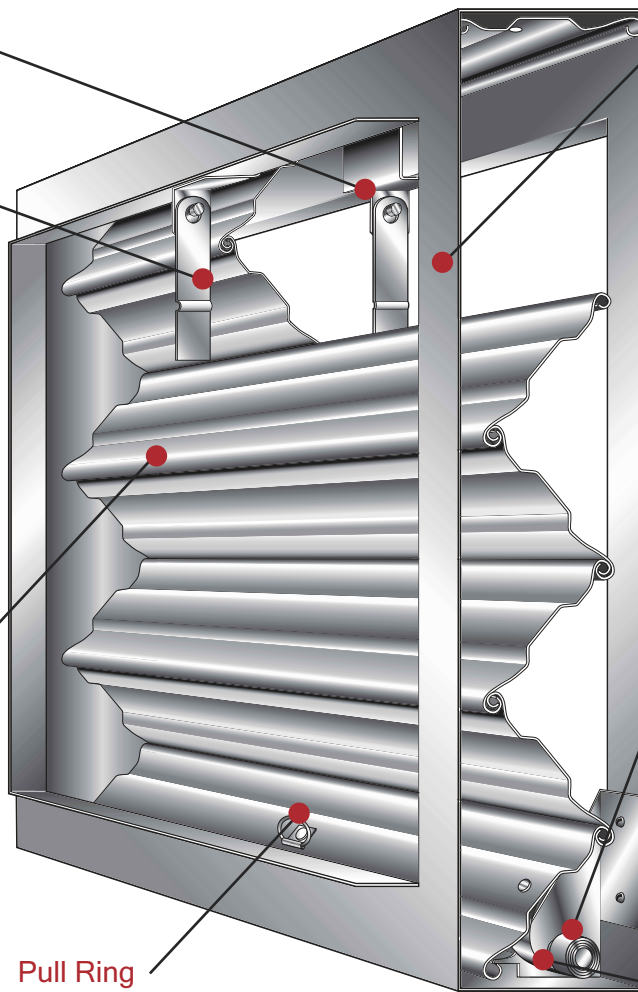

Casing

Formed to provide two continuous internal flanges not less than 30mm. Casing and components not less than 1.2mm thick cold reduced hot dipped galvanised mild steel to BS EN 10346 Grade DX51D + Z275.

Casing material options to order are Ferritic 430 type 1.4016 grade or Austenitic 316 type 1.4401 grade to BS EN 10088-2.

Side Seals

0.20mm gauge 301 stainless steel to BS EN 10088-2, available to order.

Closure Springs

Dampers are supplied with two constant force coil springs exerting a pull of not less than 35N, with one end fixed to the leading blade by rivets and the coil fitted on the spindle of the locking ramp. The spring is manufactured from Grade 302 stainless steel to BS EN 10151.

Locking Ramps

Dual locking ramps ensure positive closing action of the blade pack in horizontal or vertical installations.

Paint

All welds, seams and joints are sprayed with commercial grade water based protective paint.

Pull Ring

To aid resetting of the damper blade pack, the bottom closing blade will be fitted with a single pull ring centrally to the width for dampers up to and including 500mm wide or 500mm diameter. For all dimensions above this, two equally spaced pull rings will be fitted.

Gate Latch Release

Optional mechanism for electrical release when required. Rated 72°C (162°F),

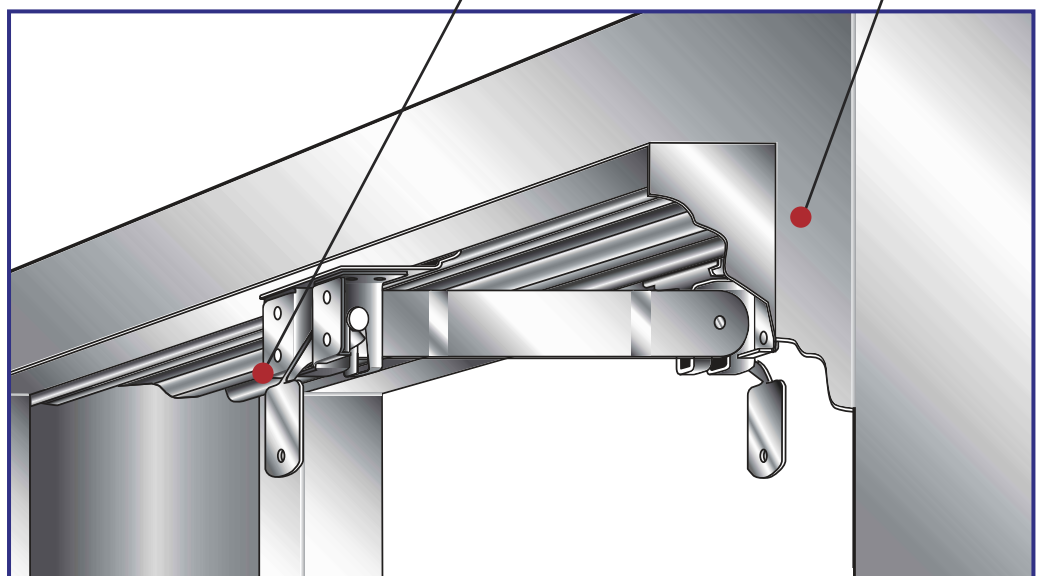



FD Series

Fire Dampers - Performance Data

Performance Data

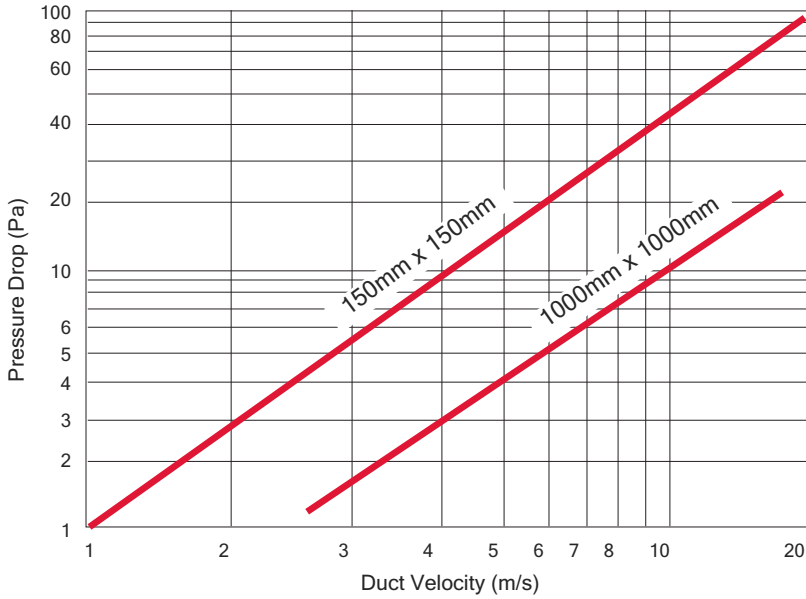

Pressure Drop Graph
Type A and Type I
Minimum free area = 91%
Velocity range 0 to 12.5 m/s

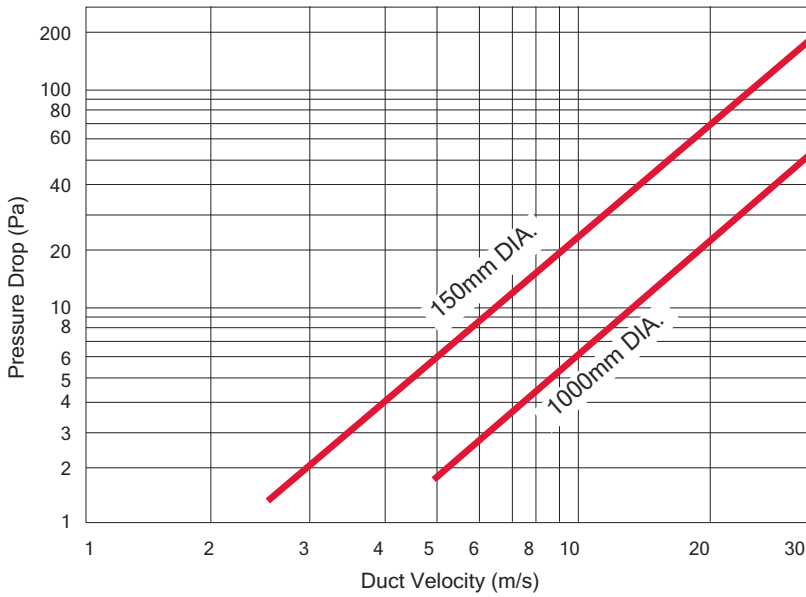

Pressure Drop Graph
Type B, Type C and Type O
Maximum unrestricted airflow
Velocity range 0 to 30 m/s

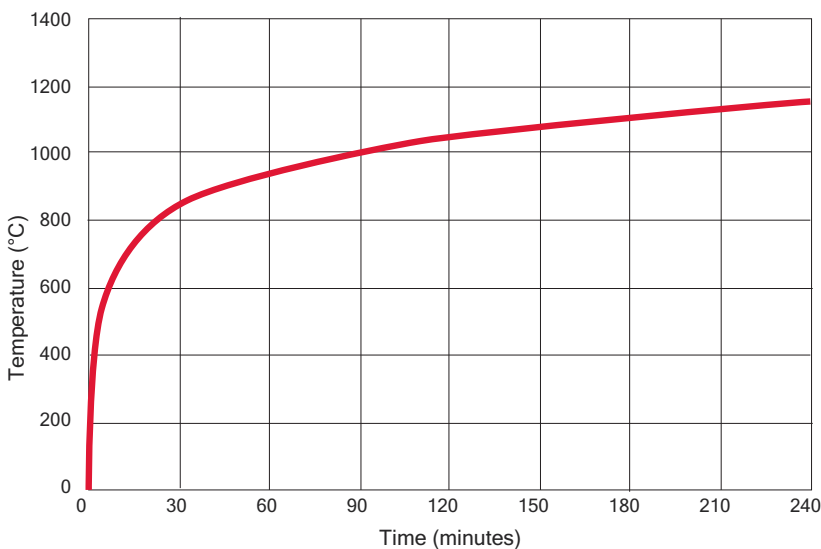

Standard Time/Temp. Curve (4 hours)
As specified in EN 1363-1

FD Series

Fire Dampers - Base Dimensions

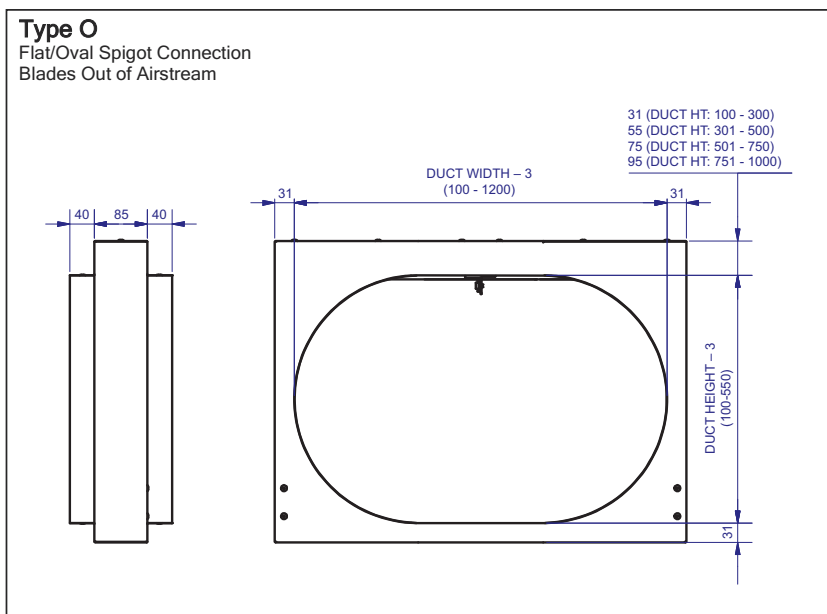
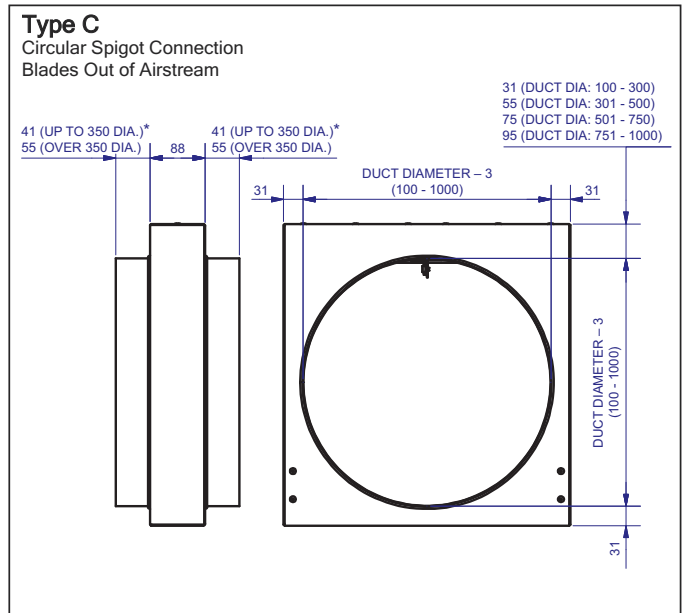
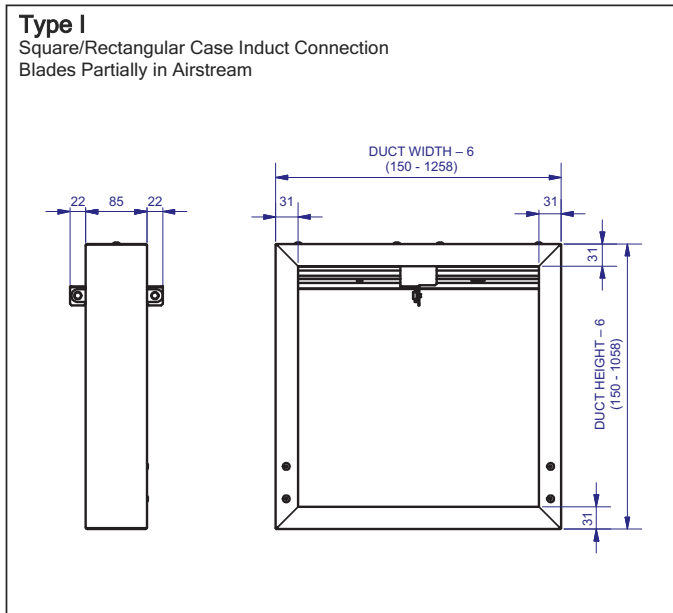
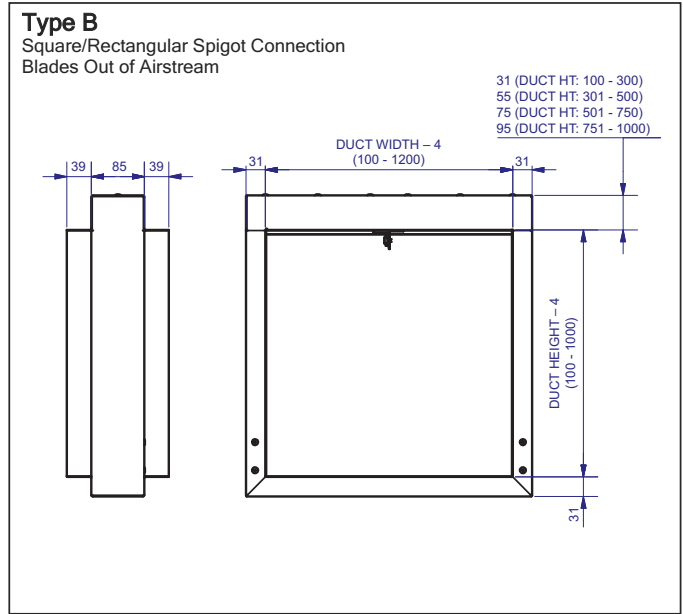
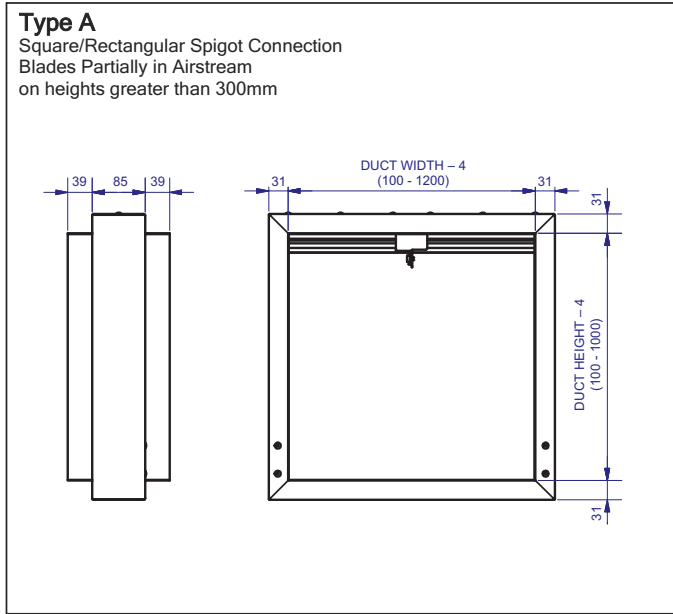

Notes:

1. All dimensions are in mm.
2. Rectangular spigoted models are supplied with actual spigot dimensions nominal less 4mm \pm 1mm.
3. Circular and Flat Oval spigoted models are supplied with actual spigot dimensions nominal less 3mm \pm 1mm.
4. For sizes greater than detailed maximum sizes, multiple section units will be supplied.
5. Where gate latches are fitted on dampers below 150mm in height or diameter release testing is only possible from opposite to ramp side. Please refer to our sales office.

Angle Frame (AF)

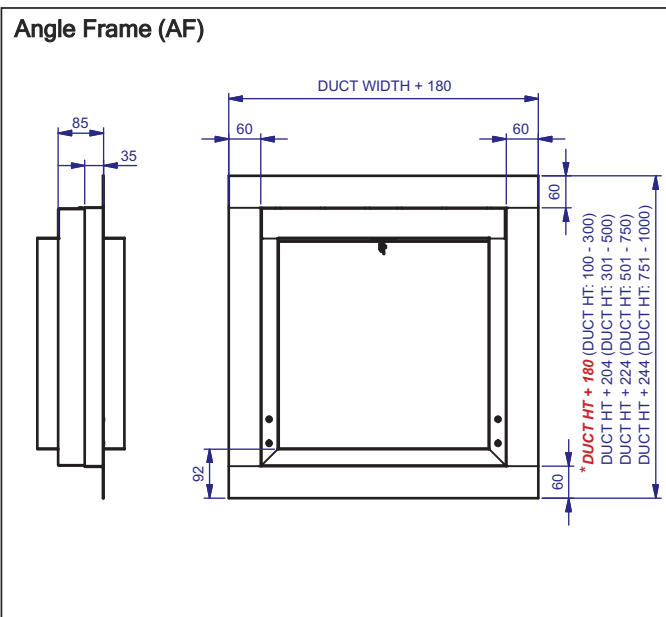

HEVAC Frame (HF)

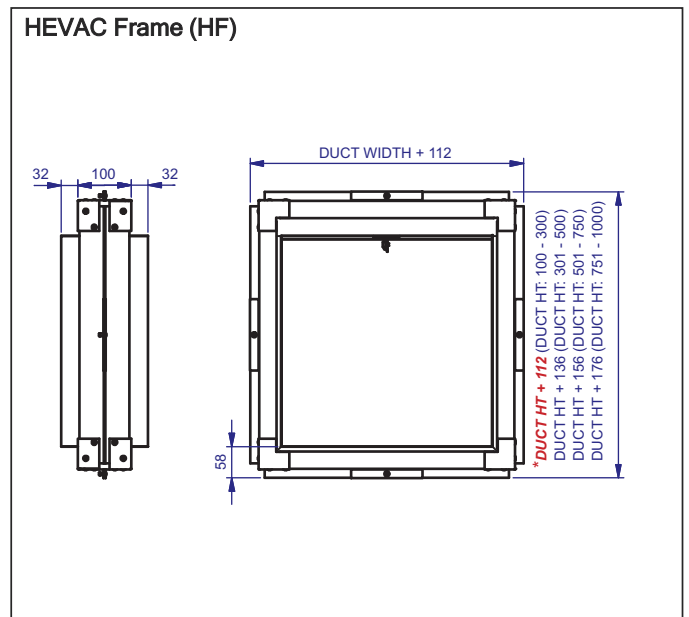

Cleats for Drop Rods (CL)

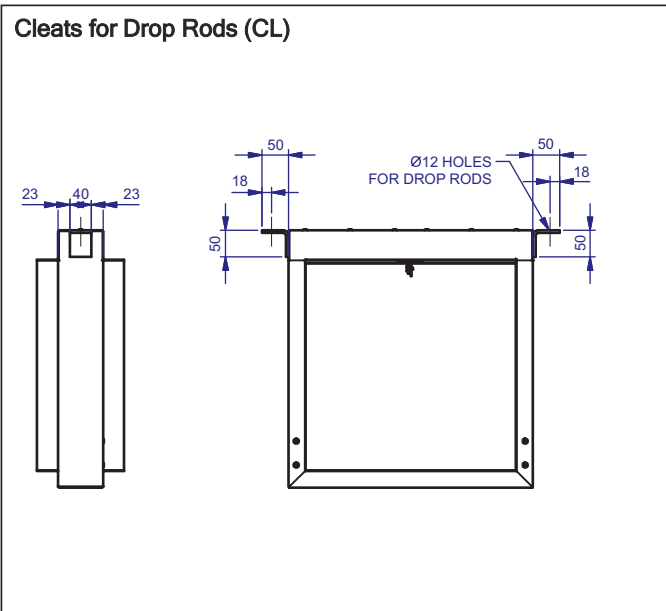

Fire Curtain (FC)

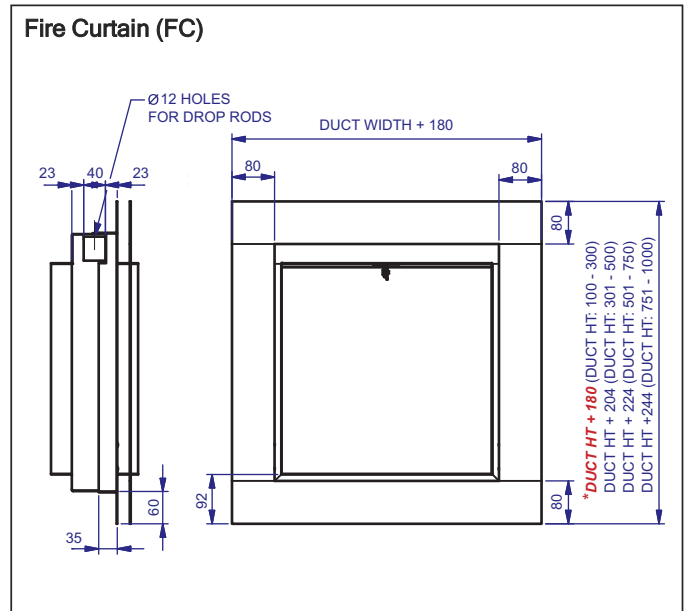

Z Frame (ZF)

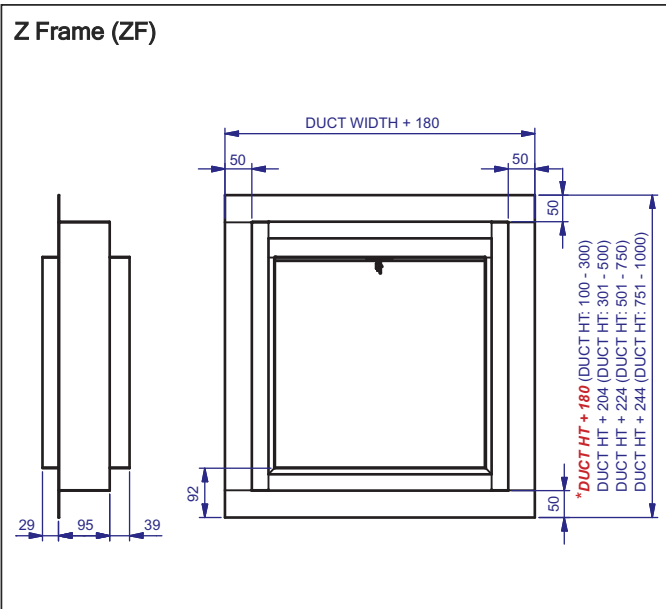

Notes:

- Dimensions with * apply for a type A damper at any height.

FD Series

Fire Dampers - Angle Frame (AF) Installation Method



Angle Frame (AF) Installation Method

The Angle Frame (AF) method offers a comprehensive installation solution for masonry walls, partition walls and concrete floors. It is CE marked for both vertical and horizontal applications and has been fire tested from both sides.

Dampers are supplied with a factory fitted 1.2mm thick welded 60mm galvanised steel angle to the damper case periphery.

Installation in masonry walls and concrete floors is effected without the need for backfilling with mortar around the damper casing.

Dampers in partition walls are installed without having to seal around the aperture with plasterboard on the non-framed side.

Cleats are available and factory fitted to the front face of the AF fixing frame. The cleats should only be used where the fire separation element is not yet in place offering a temporary installation support. The cleats must not be the sole independent method of supporting the fire damper.

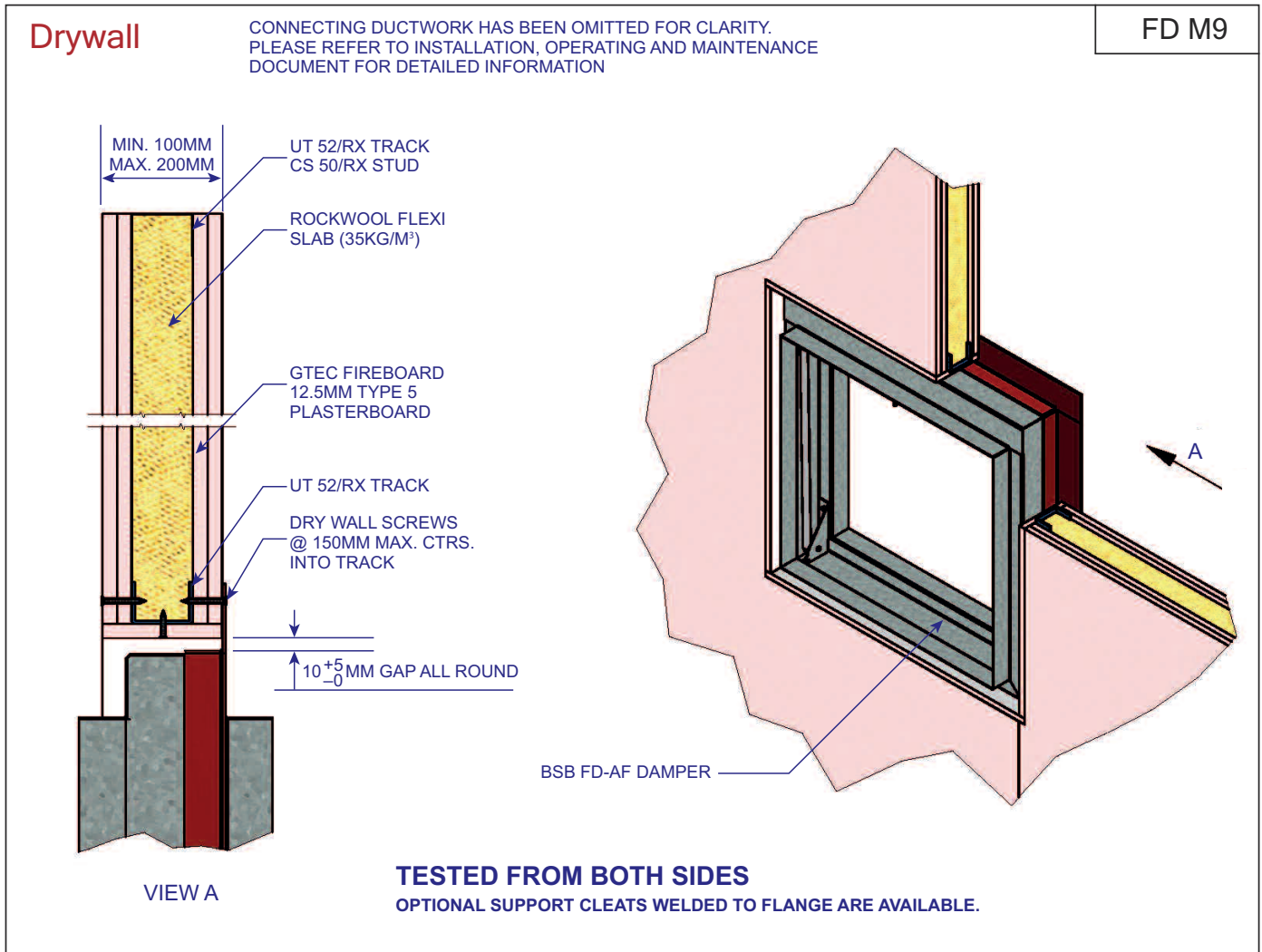
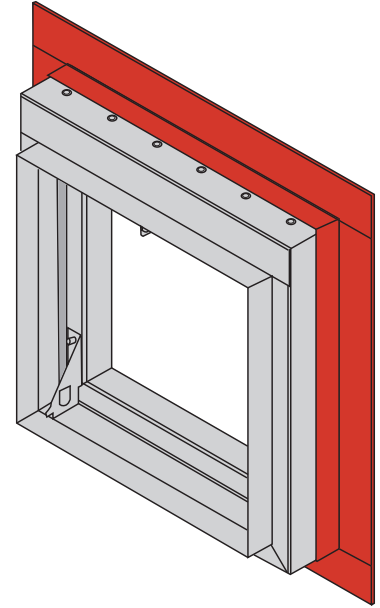

TESTED INSTALLATION METHOD SHOWN. DIFFERING INSTALLATION METHODS TO THIS, MUST BE APPROVED BY THE BUILDING CONTROL AUTHORITY (BCA) BEFORE PROCEEDING.

<p>BSB FD-AF ANGLE FRAME Fitted</p>	<p>CE 120 MINUTES FIRE RESISTANCE E120 (ve k→o)</p>
<p>Single section sizes(mm) 100 x 100 to 1200 x 1000</p>	<p>BS EN1366-2 TEST REFERENCE: 284776 AND 303868 BRE CERTIFICATE OF CONSTANCY 0832-CPR-P0006</p>

Masonry Wall

FD M10

CONNECTING DUCTWORK HAS BEEN OMITTED FOR CLARITY. PLEASE REFER TO INSTALLATION, OPERATING AND MAINTENANCE DOCUMENT FOR DETAILED INFORMATION

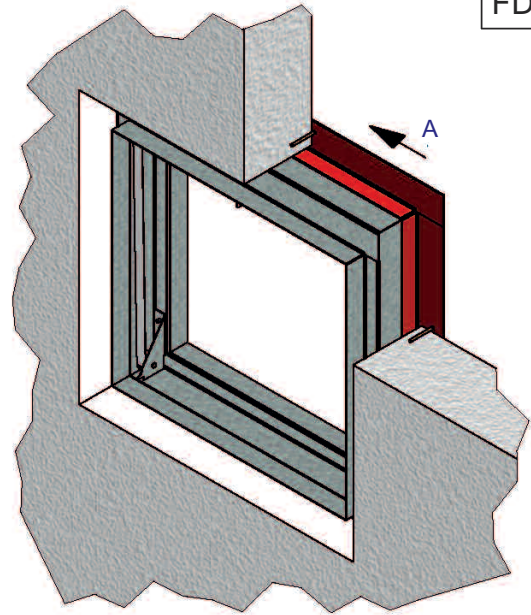
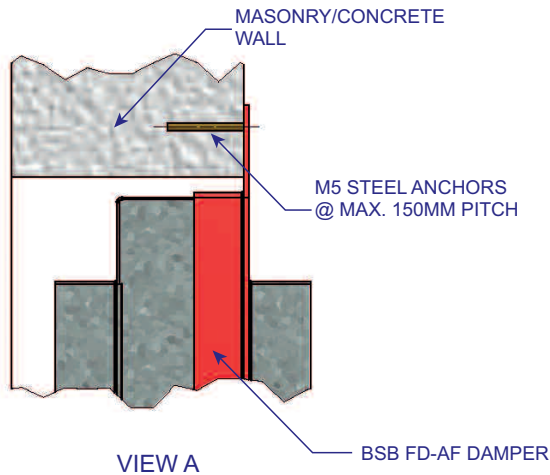

TESTED INSTALLATION METHOD SHOWN. DIFFERING INSTALLATION METHODS TO THIS, MUST BE APPROVED BY THE BUILDING CONTROL AUTHORITY (BCA) BEFORE PROCEEDING.

BSB FD-AF
ANGLE FRAME Fitted

CE 120 MINUTES FIRE RESISTANCE
E120 (ve k → o)

Single Section Sizes (mm)
100 x 100 to 1200 x 1000

BS EN1366-2 TEST REFERENCE: 284776 AND 303868
BRE CERTIFICATE OF CONSTANCY 0832-CPR-P0006

Concrete Floor

FD M11

CONNECTING DUCTWORK HAS BEEN OMITTED FOR CLARITY. PLEASE REFER TO INSTALLATION, OPERATING AND MAINTENANCE DOCUMENT FOR DETAILED INFORMATION

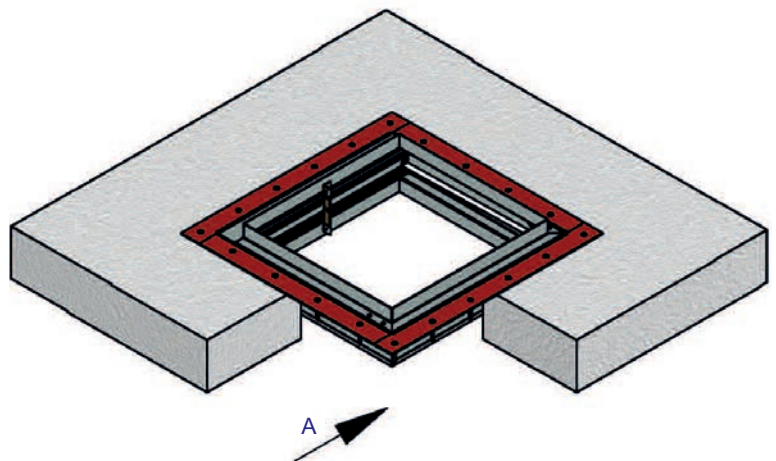
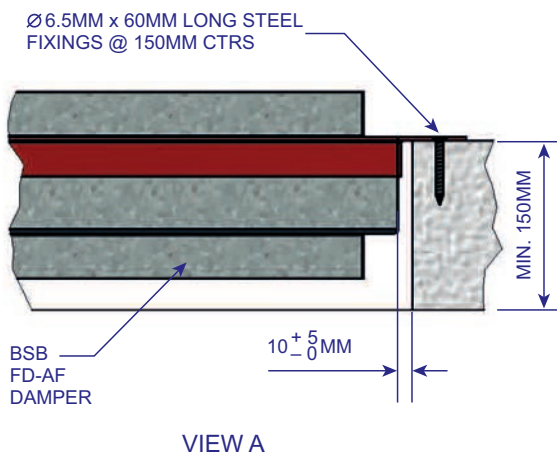

NOTE: THIS INSTALLATION WAS SUCCESSFULLY TESTED FOR 4 HOURS

TESTED INSTALLATION METHOD SHOWN. DIFFERING INSTALLATION METHODS TO THIS, MUST BE APPROVED BY THE BUILDING CONTROL AUTHORITY (BCA) BEFORE PROCEEDING.

BSB FD-AF
ANGLE FRAME Fitted

CE 120 MINUTES FIRE RESISTANCE
E120 (ho i → o)

Single Section Sizes (mm)
100 x 100 to 1200 x 1000

BS EN1366-2 TEST REFERENCE: 282572
BRE CERTIFICATE OF CONSTANCY 0832-CPR-P0006

FD Series

Fire Dampers - HEVAC Frame (HF) Installation Method



HEVAC/HVCA Frames

The HEVAC/HVCA approved factory fitted Installation Frame is designed to allow expansion of the damper under fire conditions, without affecting its integrity or the construction it is installed within.

Builders Ties

For securing the assembly into the builders work structure as specified by the specifying/authorising authority. In brick or Blockwork walls the fixing tie tabs must be bent out and be securely built into the mortar joints between the brick or Blockwork.

Installation within reinforced concrete walls and floors, the builders tie tabs shall be bent out and tied back with stainless steel wire to the reinforcing bars that should be left protruding into the structural opening or to "eye bolts" but so as not to interfere with the installation of the damper. The gap between the installation frame and the builders work shall be backfilled with mortar or concrete on both sides of the upstand flange to the satisfactory requirements of the approving authoritative body.

Corner Bracket

The corner bracket is rivetted (using aluminium rivets) to the "Z" Section which makes the frame. This bracket allows the frame to expand under fire conditions without affecting the integrity of the construction it is installed within.

Expansion Spacers

These spacers are fitted into each corner to permit expansion of the fire damper within the construction of the frame.

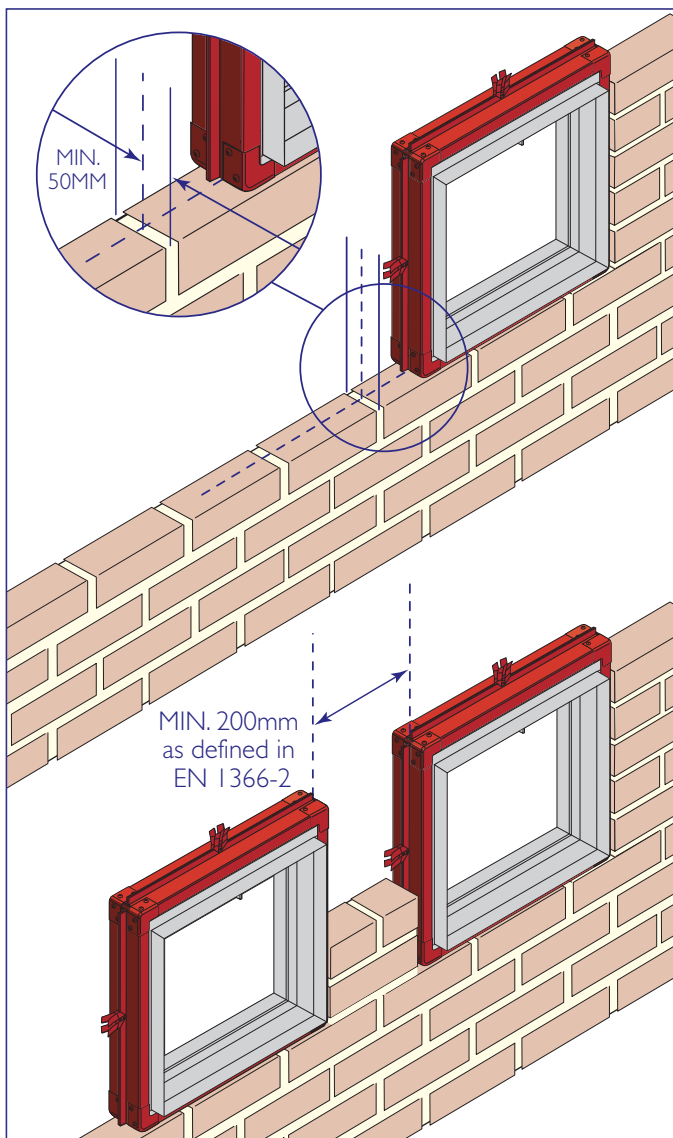
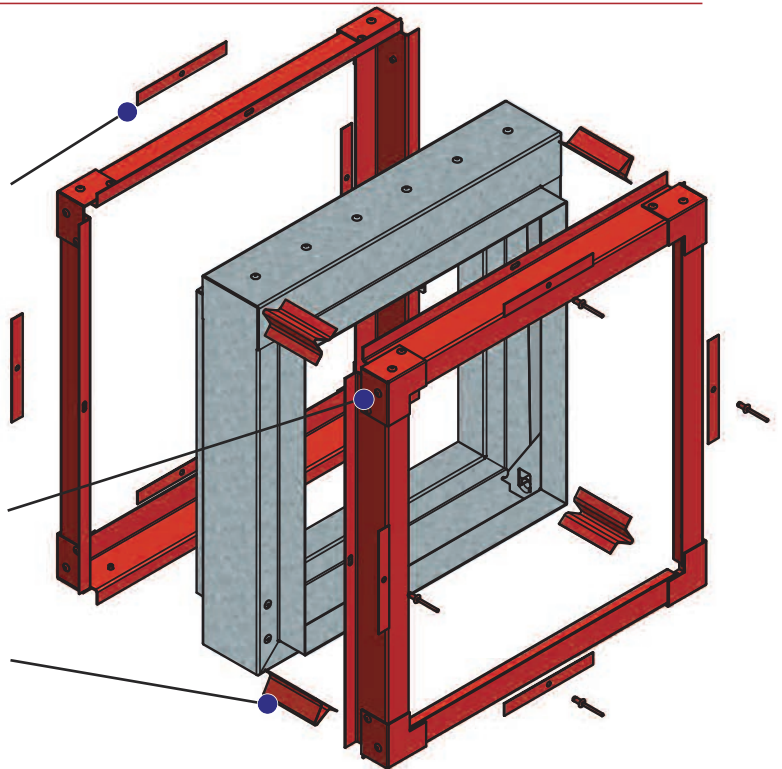

Installation Codes of Practice

The frame should be installed centrally within the thickness of the surrounding wall or floor. Or, in the case of thick walls or floors, the centre line of the frame should be at least 50mm away from the nearest face.

Where more than one duct penetrates a wall or floor, adjacent fire damper assemblies should be separated by builder's work of a minimum thickness of 200mm. During installation, all fixing tabs should be bent out and built into the surrounding structure so as to ensure "positive fixing into the surrounding builder's work".

The illustrated detail on this page is BSB's interpretation of the HEVAC/HVCA Installation Frame specification. For additional details, contact our sales office.

Special Note:

All fire damper installations should be carried out to the satisfaction of the appropriate district surveyor, fire officer, building control authority and/or specifying authority as other approved methods of installation may well be used.

Installation Parameters

FD Series Fire Dampers are designed for application in normal dry filtered air systems. If exposed to fresh air intakes and/or inclement conditions the damper should be subject to a planned inspection programme.

Installations involving corrosive and/or aggressive hostile environmental conditions (e.g. swimming pools) may invalidate our warranty and should be referred to our Sales Office.

Separation between fire dampers and between fire dampers and construction elements

In accordance with EN 1366-2 and the direct application rules, where two fire dampers are installed side by side within a fire separating element. There must be 200mm clear separation between damper casings.

Dampers installed must also be a minimum of 75mm between the damper casing and the construction element.

Please refer to EN 1366-2 section 7.3 figures 11 and 12.

FD M2
 DW/145 M3

Block/Masonry Wall

CONNECTING DUCTWORK HAS BEEN OMITTED FOR CLARITY

SECURING OF BUILDING TIES:
 EITHER, CUT 150MM LONG X 50MM DEEP POCKETS INTO SURROUNDING CONSTRUCTION, BEND OUT TABS INTO POCKETS AND BACKFILL.
 OR, USE 5MM DIA STEEL ANCHORS (MIN) AND 1.5MM DIA STEEL WIRE (MIN) AROUND BENT-OUT TABS & ANCHORS TO FIX TO SURROUNDING CONSTRUCTION, PRIOR TO BACKFILL.

BSB FD-HF HEVAC FRAME Fitted	120 MINUTES FIRE RESISTANCE E120 (ve i → o)
Single Section Sizes (mm) 100 x 100 to 1200 x 1000	BRE CERTIFICATE OF CONSTANCY: 0832-CPR-P0006

FD M1
 DW/145 M3

Concrete Floor

CONNECTING DUCTWORK HAS BEEN OMITTED FOR CLARITY.
 PLEASE REFER TO INSTALLATION, OPERATING AND MAINTENANCE DOCUMENT FOR DETAILED INFORMATION

SECURING OF BUILDING TIES:
 EITHER, CUT 150MM LONG X 50MM DEEP POCKETS INTO SURROUNDING CONSTRUCTION, BEND OUT TABS INTO POCKETS AND BACKFILL.
 OR, USE 5MM DIA STEEL ANCHORS (MIN) AND 1.5MM DIA STEEL WIRE (MIN) AROUND BENT-OUT TABS & ANCHORS TO FIX TO SURROUNDING CONSTRUCTION, PRIOR TO BACKFILL.

BSB FD-HF HEVAC FRAME Fitted	120 MINUTES FIRE RESISTANCE E120 (ho i → o)
Single Section Sizes (mm) 100 x 100 to 1200 x 1000	BRE CERTIFICATE OF CONSTANCY 0832-CPR-P0006

FD Series

Fire Dampers - Pattress with Cleat Accessories



Drywall

FD M6

CONNECTING DUCTWORK HAS BEEN OMITTED FOR CLARITY.

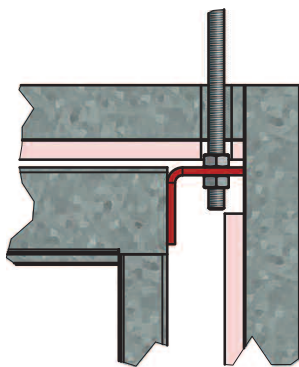
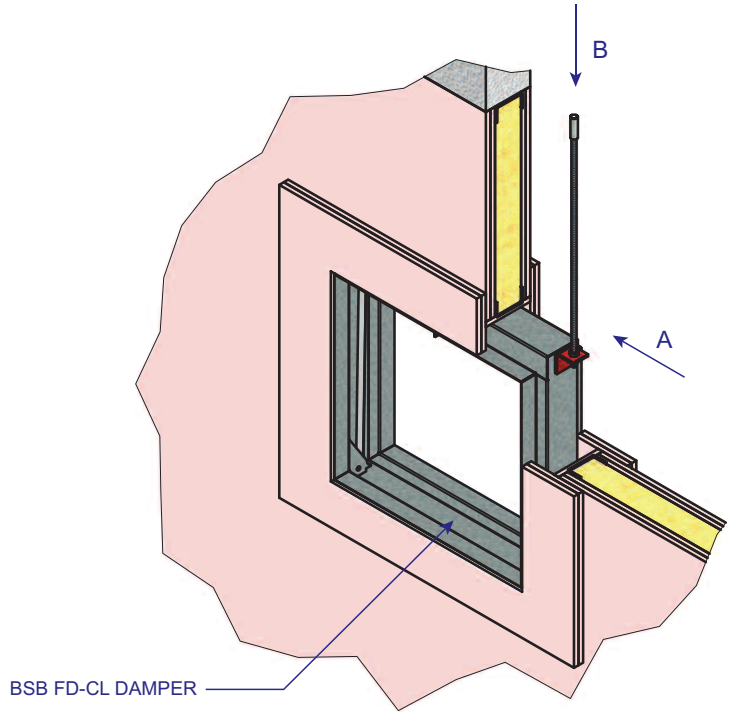
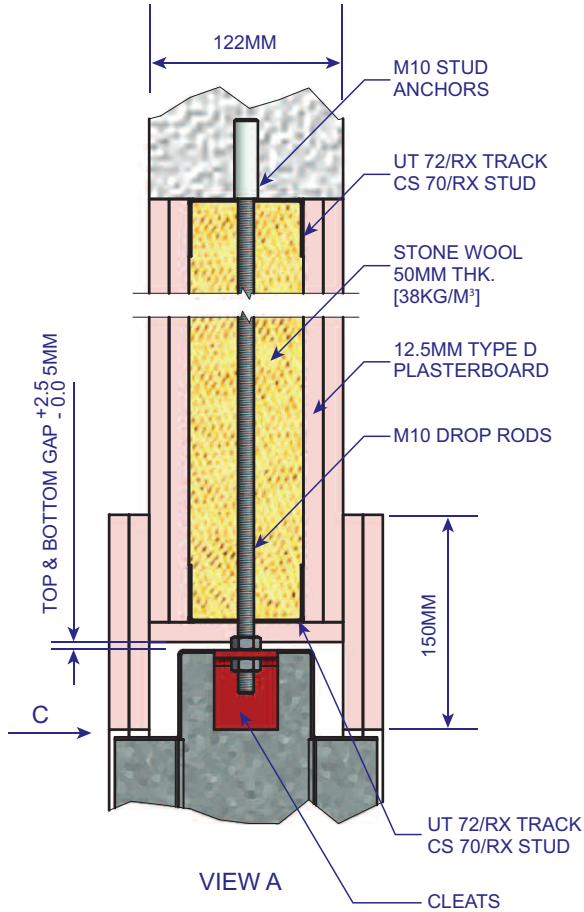

VIEW C

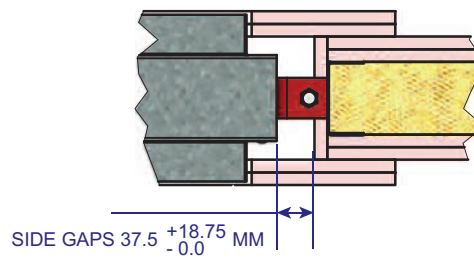

VIEW B

CLEATS:
THE INSTALLATION SHOWN REFERS TO A PATTRESS INSTALLATION METHOD WITH CLEATS FITTED AS AN ACCESSORY.

TESTED INSTALLATION METHOD SHOWN. DIFFERING INSTALLATION METHODS TO THIS, MUST BE APPROVED BY THE BUILDING CONTROL AUTHORITY (BCA) BEFORE PROCEEDING.

<p>BSB FD-CL</p>	<p>CE 120 MINUTES FIRE RESISTANCE E120 (ve i → o)</p>
<p>Single section sizes(mm) 100 x 100 to 1200 x 1000</p>	<p>BS EN1366-2 TEST REFERENCE: 258320 BRE CERTIFICATE OF CONSTANCY 0832-CPR-P0006</p>

Assessed to BS 476-20/22 for up to 2 hours

FD FC

**FIRE CURTAIN -
ANGLE FRAME AND CLEATS**
Damper size:
Min. 100mm x 100mm.
Max. 1000mm x 1000mm

Labels in diagram:
 FIRE RATED
 FACTORY FITTED FULL FACED FIXING FLANGE
 FOR HANGER AND SUPPORT DETAILS REFER TO DW144
 CLEATS FACTORY FITTED TO DAMPER SO AS NOT TO IMPAIR DAMPER BLADES
 WIRE MESH ACROSS DUCT SPIGOTS TO PROTECT AGAINST ACCIDENTAL CONTACT WITH BLADES AND RELEASE MECHANISM
 1.5mm GALVANISED STEEL SPIGOT PLATE (FOR 30 MIN. CURTAIN)
 NB: CURTAIN MATERIAL MUST NOT BE COMPRESSED
 80mm MIN.
 60mm MIN.
 FLEXIBLE FIRE/SMOKE BLANKET

Assessment reference: CC256681
BS 476-20/22: 2 hours

FD I

REMOTE FROM WALL
Damper size:
Min. 100mm x 100mm.
Max. 1000mm x 1000mm

Labels in diagram:
 FOR HANGER AND SUPPORT REFER TO DW144
 INTUMESCENT BEAD (OR PURPOSE BUILT COLLAR) TO MEET FIRE RATED DUCTWORK REQUIREMENTS
 FIXINGS AND HANGERS FOR FIRE RATED DUCTWORK TO HAVE SAME FIRE RATING AS DUCT - SEE STRUCTURAL FIXING SOLUTIONS
 EXPANSION CLEARANCE 3mm PER 300mm WIDTH AND HEIGHT OF DUCT TO CATER FOR EXPANSION
 FIRE RATED DUCTWORK
 2000mm MAX.
 NON-COMBUSTIBLE FIRE STOPPING MATERIAL
 e.g MINERAL WOOL WITH DENSITY GREATER THAN 80kg/cuM
 ACCESS PANEL FITTED TO APPROPRIATE SIDE OF DAMPER TO PERMIT SAFE AND EASY ACCESS TO BLADES AND FUSIBLE LINK RELEASE MECHANISM. (PREFERRED SOLUTION: ACCESS PANEL TO BE AT LEAST 250mm SQUARE TO ENSURE EASY ACCESS EXPAND DUCT TO ACCOMMODATE THIS SIZE PANEL)

Assessment reference: CC256681
BS 476-20/22: 120 minutes

OTHER INSTALLATION METHODS ARE AVAILABLE

* If your proposed installation method has minor variations to that shown, please confirm acceptance with the local Building Control Authority (BCA) before proceeding. Manufacturers are not able to "approve" specific installation methods. It is generally accepted that EN 1366-2 tested installations will fulfil any requirements to BS 476-20/22 as the test method is much more severe.

FD Series

Fire Dampers - Fusible Link Release and Multiple Assemblies



Fusible Link Release

Straight Bar Fusible Link (Standard)

The standard fusible link will be supplied and rated at 72°C unless otherwise specified.

Gate Latch Link Option

Providing a trigger operation feature, this self-locating and easily resettable cassette can be used with either the solenoid or electro-magnet controls - or, as a standard component to assist the engineer in the resetting of the fire damper during regular inspection and maintenance procedures.

Below 150mm in height or diameter release testing only possible from opposite to ramp side.

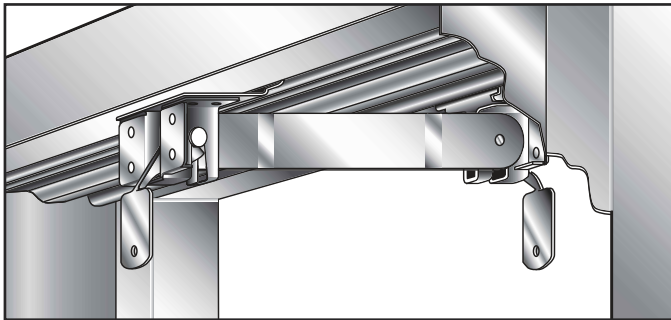
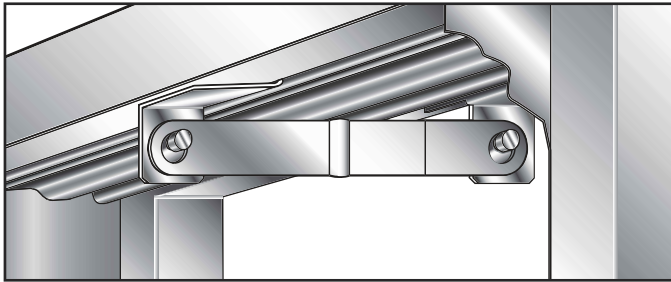

BSB FD series folding blade fire dampers are supplied with fusible links rated and designed to operate at 72°C as standard.

Fire dampers fitted with links rated at any other temperature other than 72°C will not be CE marked.

Replacement links for existing fire dampers will need to match the type of link bracket that has been supplied (please see below). If in doubt, please refer to our Sales Office.

Standard Link (LS)

Supplied as standard, the BSB straight bar link has a formed reinforcing swage and two location holes (125mm long x 18mm wide, with 2 off 10mm diameter holes at 107mm centres).

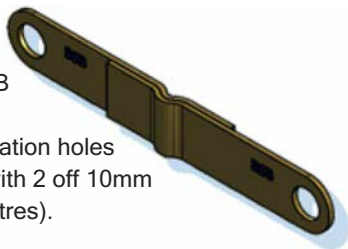

Gate latch Link (LG)

Used with the Gate latch release mechanism to assist the engineer in testing and resetting of fire dampers during routine inspection and maintenance procedures

(120mm long x 23mm wide, with 2 off 10mm diameter bosses at 103mm centres).

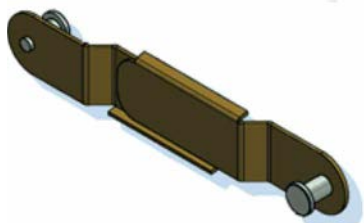

Multiple Assemblies

FD Series dampers can be supplied in multiple module sections to achieve requested sizes larger than the maximum manufactured single module units.

Such units and their installation method must be approved by the BCA before installation. For this, consideration must be given to additional structural steelwork that might be needed to support the weight of the damper. BSB cannot offer or approve supporting structures for multiple assemblies.

Illustrated are several variants of multiple module arrangements.

When there are transportation restrictions, large multiple units will be shipped in individual sections for site assembly by others. Joining strips are supplied un-drilled unless requested otherwise. Large multiple units required to be shipped fully assembled will incur additional packing/shipping costs. Please contact our sales office for further information.

BSB can manufacture to individual specifications and applications. Illustrated are standard variants with other variants available to order.

Vertical Mounting

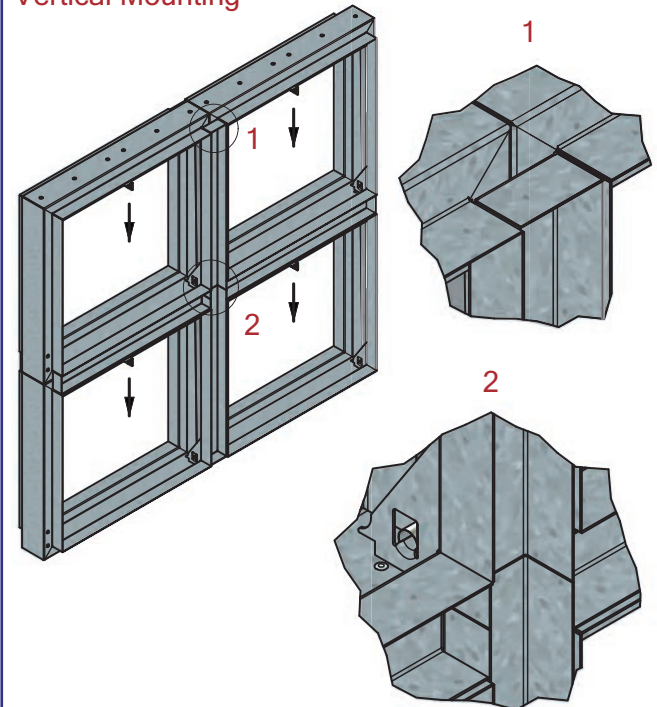

Horizontal Mounting

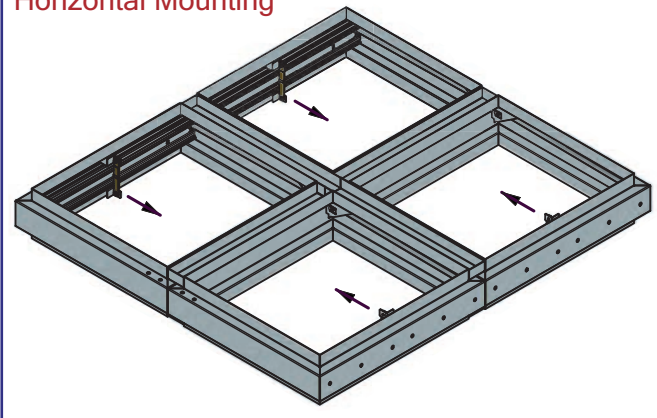

Mechanical Visual Indicator

To provide local indication of the blade status.

When the indicator appears in the bulb, this shows that the blades are closed.

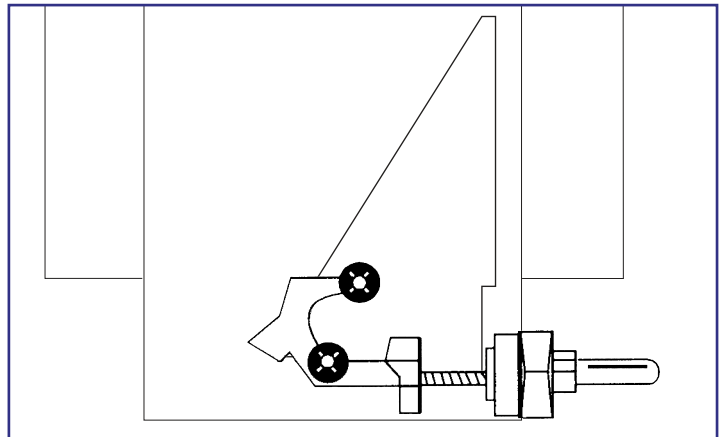

Single Pole Microswitch

To provide remote indication of the blade status. As the leading blade travels close towards the locking ramp, it makes contact with the arm and operates the change over switch to provide a remote closed signal.

The Single Pole Microswitch is supplied as a dependent snap action contact 1NO + 1NC.

For indication of damper closed, terminals 13 and 14 should be used.

Degree of protection: IP66.

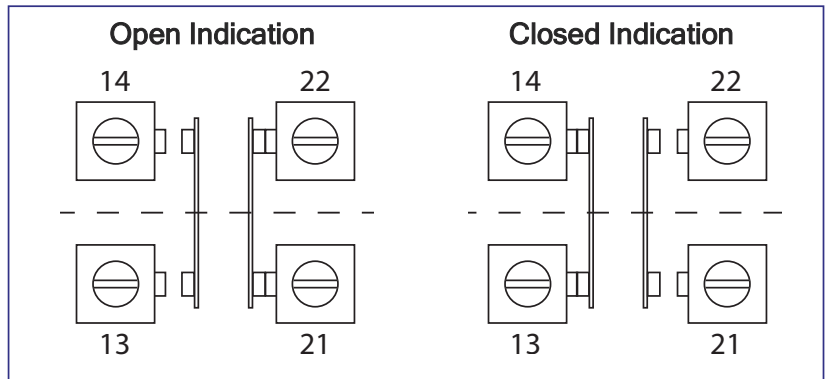
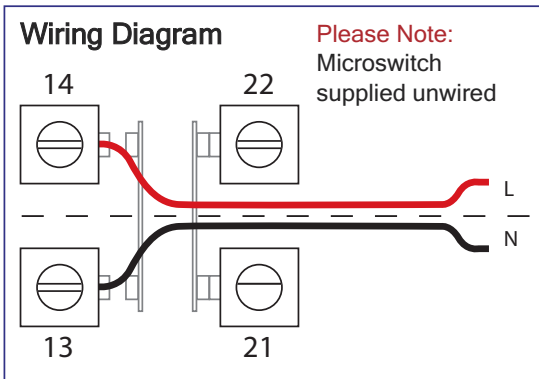
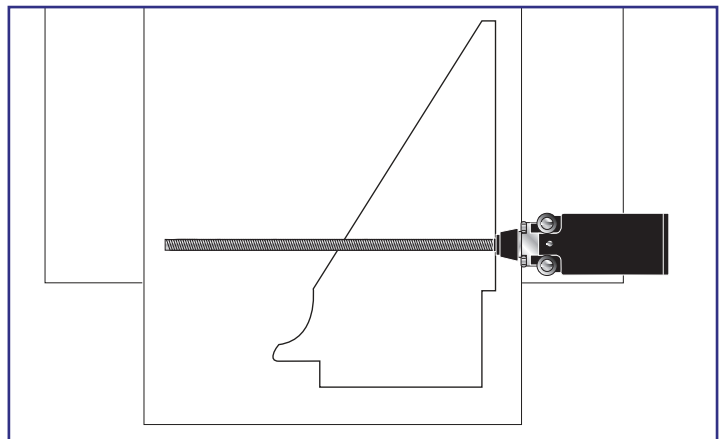

V4 Sealed Microswitch

To provide remote indication of the blade status.

As the leading blade travels over the locking ramp, the lever is depressed and operates the switch. Factory fitted.

Degree of protection: Casing and Outlet IP67

Lead Length: 460mm

Connection details:

- Common (1) Black lead
- Normally open (4) Blue lead
- Normally closed (2) Brown lead

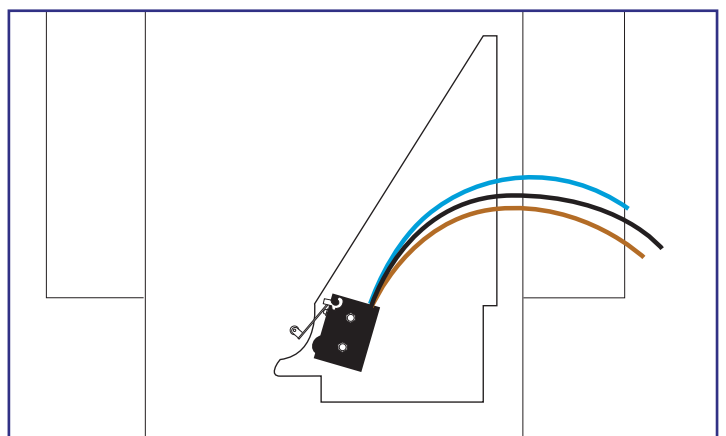

FD Series

Fire Dampers - Weight Charts



Weight Chart (kg approx.)

Height (mm)	Width (mm)											
	100	200	300	400	500	600	700	800	900	1000	1100	1200
100	2.0	2.5	3.0	4.0	4.5	5.0	5.5	6.5	7.0	8.0	8.5	9.0
200	2.5	3.0	4.0	4.5	5.0	6.0	6.5	7.5	8.0	9.0	9.5	10.5
300	3.0	4.0	4.5	5.5	6.0	7.0	8.0	9.0	9.5	10.5	11.0	12.0
400	3.5	4.5	5.5	6.5	7.5	8.5	9.5	10.5	11.5	12.5	13.5	14.5
500	4.5	5.5	6.5	7.5	8.5	9.5	10.5	12.0	13.0	14.0	15.0	16.0
600	5.0	6.0	7.5	8.5	9.5	11.0	12.0	13.5	14.5	16.0	17.0	18.5
700	5.5	6.5	8.0	9.0	10.5	11.5	13.0	14.5	15.5	17.0	18.0	19.5
800	6.0	7.5	9.0	10.5	11.5	13.0	14.5	16.0	17.5	19.0	20.5	21.5
900	6.5	8.0	9.5	11.0	12.5	14.0	15.5	17.5	19.0	20.5	22.0	23.5
1000	7.0	9.0	10.5	12.0	13.5	15.0	17.0	18.5	20.5	22.0	23.5	25.0

Weight Chart Circular (kg approx.)

Nom. dia. (mm)	Width (mm)		
	FDC	FDC+HF	FDC+AF
100	1.5	3.5	3.0
150	2.5	4.5	4.0
200	3.0	5.5	4.0
250	3.5	6.5	5.0
300	4.5	7.5	6.0
350	6.5	10.0	8.0
400	8.0	11.5	10.0
450	9.0	13.5	11.0
500	10.5	15.0	13.0
550	12.0	17.0	15.0
600	13.5	19.0	16.0
650	15.0	21.0	18.0
700	16.5	22.5	20.0
750	18.0	24.5	22.0
800	20.5	27.5	24.0
850	22.5	29.5	26.0
900	24.5	32.0	28.0
950	26.5	34.5	31.0
1000	28.5	37.0	33.0

Weight Chart + Hevac Frame (kg approx.)

Height (mm)	Width (mm)											
	100	200	300	400	500	600	700	800	900	1000	1100	1200
100	3.5	4.5	5.5	6.5	7.5	8.5	8.5	11.0	12.0	13.0	14.0	15.0
200	4.5	5.5	6.5	7.5	8.5	10.0	11.0	12.0	13.5	14.5	15.5	16.5
300	5.5	6.5	8.0	9.0	10.0	11.5	12.5	14.0	15.0	16.0	17.5	18.5
400	6.5	8.0	9.0	10.5	11.5	13.0	14.5	16.0	17.5	18.5	20.0	21.5
500	7.5	9.0	10.5	11.5	13.0	14.5	16.0	17.5	19.0	20.5	22.0	23.5
600	8.5	10.0	11.5	13.0	14.5	16.5	18.0	19.5	21.5	23.0	24.5	26.0
700	9.5	11.0	12.5	14.0	15.5	17.5	19.0	21.0	22.5	24.0	26.0	27.5
800	10.5	12.0	14.0	15.5	17.5	19.0	21.0	23.0	24.5	26.5	28.5	30.0
900	11.5	13.0	15.0	17.0	18.5	20.5	22.5	24.5	26.5	28.5	30.5	32.5
1000	12.0	14.0	16.0	18.0	20.0	22.0	24.0	26.0	28.5	30.5	32.5	34.5

Weight Chart + Angle Frame (kg approx.)

Height (mm)	Width (mm)											
	100	200	300	400	500	600	700	800	900	1000	1100	1200
100	2.5	3.5	4.5	5.0	6.0	6.5	7.5	8.5	9.5	10.0	11.0	12.0
200	3.5	4.5	5.0	6.0	7.0	7.5	8.5	9.5	10.5	11.5	12.5	13.0
300	4.0	5.0	6.0	7.0	8.0	9.0	10.0	11.0	12.0	13.0	14.0	15.0
400	5.0	6.0	7.5	8.5	9.5	10.5	11.5	13.0	14.0	15.5	16.5	17.5
500	6.0	7.0	8.5	9.5	10.5	12.0	13.0	14.5	16.0	17.0	18.5	19.5
600	6.5	8.0	9.5	11.0	12.0	13.5	15.0	16.5	18.0	19.5	20.5	22.0
700	7.5	9.0	10.0	11.5	13.0	14.5	16.0	17.5	19.0	20.5	22.0	23.5
800	8.0	10.0	11.5	13.0	14.5	16.0	17.5	19.5	21.0	22.5	24.0	26.0
900	9.0	10.5	12.5	14.0	15.5	17.5	19.0	21.0	22.5	24.5	26.0	27.5
1000	10.0	11.5	13.5	15.0	17.0	18.5	20.5	22.5	24.5	26.0	28.0	29.5

Fire Dampers - Testing and Maintenance

It is a requirement for fire protection systems to be regularly inspected, tested and maintained. As integral components of such systems, BSB FD Series fire dampers should be subjected to a planned maintenance programme.

In accordance with BS 9999 Annex W.1, inspection should be undertaken every year, though local regulations may override this, with periodic inspection being carried out more frequently where corrosive or dirty conditions prevail.



BSB recommend a maximum of one year between inspections. We also recommend that inspections begin more frequently and are only reduced to one year if conditions are proven to allow. The maintenance log should be reviewed at each inspection and the frequency adjusted as required dependent upon findings.

Testing and resetting will need to be undertaken through an access panel. The internal damper elements will need to be checked for corrosion, obstructions and accumulated dirt/dust. Cleaning should be undertaken using a soft cloth with a light application of light lubricant. Only a thin film of lubricant should be applied.



Please refer to our Operation and Maintenance details for further information and instructions for drop testing.

A regular test and maintenance programme will extend the working life of the fire safety system.

BSB are pleased to offer a comprehensive fire damper maintenance service. Please contact our Sales Office for details.

FD Series dampers are designed for normal dry filtered air systems and should be included within a programme of planned inspections.

Records of each damper installation and location are recommended and should include the condition of the dampers at each inspection with any action taken recorded and kept in an accessible location, as these products come under the requirements of the Regulatory Reform (Fire safety) Order (RRFSO).

Inspection and maintenance programmes may need to be repeated more regularly if the dampers are exposed to inclement and dusty conditions or fresh air intakes where the frequency of such checks should be developed based on site experience.



Recycling

BSB recognises the need to preserve resources and reduce emissions and are actively working towards and introducing more efficient ways of manufacturing.

BSB supports and recommends that good waste management practice be adopted on all new and refurbishment projects, regardless of size. This not only reduces emissions, preserves raw materials and saves energy, but also reduces costs long term.

BSB are proud that their dampers are 95% minimum recyclable.

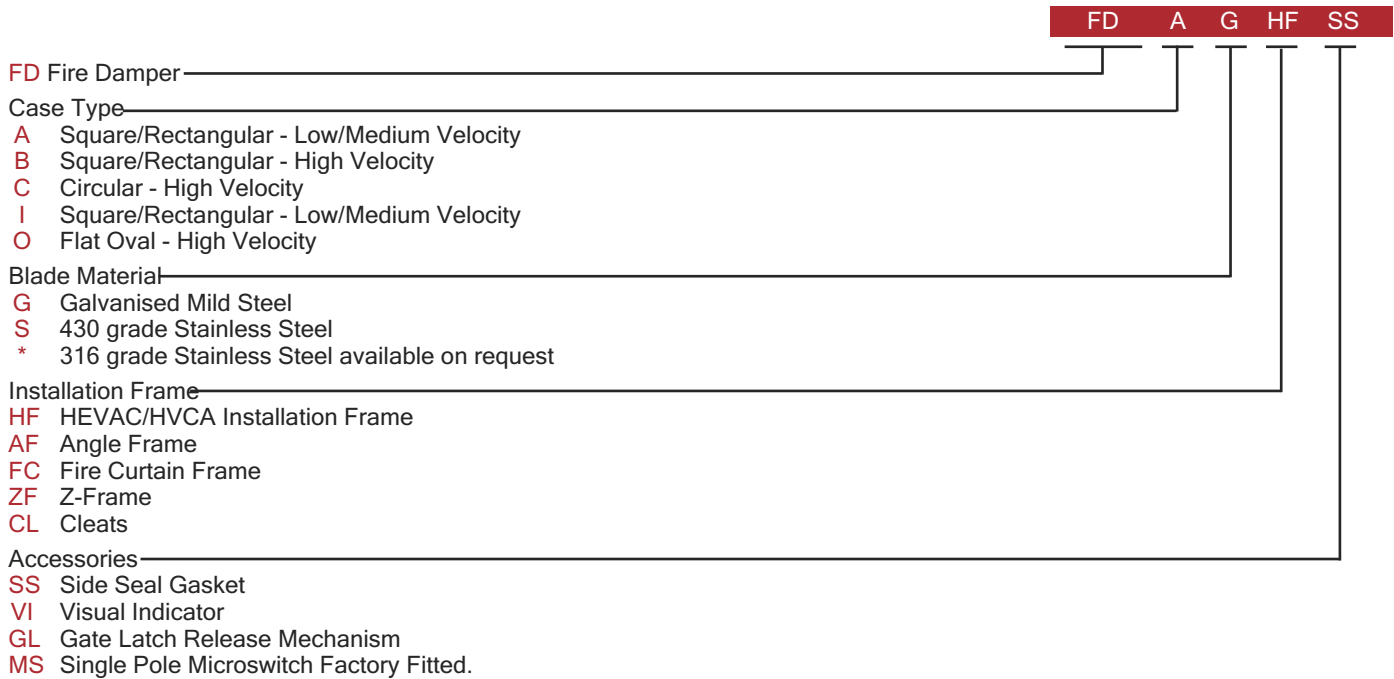

Air, Fire and Smoke Control Products in the Range:



For full details of the complete Product Range, please refer to our individual product brochures, sales office or website.